

FLEX TABLE





Recommended use	School, university, educational institutions, seminars
Ausführung	Table legs made of powder-coated steel tubing (Ø 50 mm), which are firmly screwed to the multiplex board. Very sturdy, washable tabletop made of sustainable birch multiplex material. Optional four flush-mounted, recessed decorative elements on the top of the table slats at the table leg positions.
Colours of table legs	<p>05 09 06 73 11 31 16 54 04</p> <p>colour powder coated</p>
Table tops	High-quality, extra-strong birch multiplex board, raw and finely sanded edges, coated with HPL, thickness 28.6 mm. Both components are FSC and PEFC certified and come from ecologically, economically and socially sustainable forestry.
Edge finish	<p>raw, finely ground</p> <p>oiled, finely sanded (for an additional charge)</p> <p>blackened, finely ground (for an additional charge)</p>
Decorative element	<p>identical to the table leg colour</p> <p>snow white, identical to the HPL surface</p> <p>without decorative element</p>

PRODUCT INFORMATION

● 05 Snow White	RAL 9002	NCS S 1002-G50Y
● 09 Granite Grey	RAL 7037	NCS S 5000-N
● 06 Graphite Black	RAL 9005	NCS S 9000-N
● 73 Warm Grey	-	NCS S 5005-Y20R
● 11 Aqua Blue	RAL 210 70 10	NCS S 2020-B10G
● 31 Coral Red	RAL 040 40 60	NCS S 2070-Y80R
● 16 Sun Yellow	-	NCS S 0580-Y10R
● 54 Fern Green	-	NCS S 3020-G
● 04 Forest Green	RAL 6005	NCS S 7020-G

Stand 20|01|2025

Glides/Castors	<p>Table legs with 2 x universal glides with height adjustment and 2 x large, soft double castors with locking function, for hard floors.</p> <div style="display: flex; justify-content: space-around; align-items: center;"> <div style="text-align: center;">  <p>A</p> </div> <div style="text-align: center;">  <p>B</p> </div> </div> <div style="text-align: right; margin-top: 10px;"> <p>A Adjustable foot B Soft castor with locking function</p> </div>																
Table height	<p>Size 2 – 53 cm Size 3 – 59 cm Size 4 – 64 cm Size 5 – 71 cm Size 6 – 76 cm Size 7 – 82 cm</p> <p>accordingly DIN EN 1729</p>																
Weight	<table border="0"> <tr><td>Single table</td><td>15.9 kg</td></tr> <tr><td>Double table</td><td>23.1 kg</td></tr> <tr><td>Triangular table</td><td>10.7 kg</td></tr> <tr><td>Trapezoidal table</td><td>19.0 kg</td></tr> <tr><td>Semicircular table</td><td>28.4 kg</td></tr> <tr><td>Lift group table</td><td>44.5 kg</td></tr> <tr><td>Flower group table</td><td>46.5 kg</td></tr> <tr><td>Workbench</td><td>75.0 kg</td></tr> </table>	Single table	15.9 kg	Double table	23.1 kg	Triangular table	10.7 kg	Trapezoidal table	19.0 kg	Semicircular table	28.4 kg	Lift group table	44.5 kg	Flower group table	46.5 kg	Workbench	75.0 kg
Single table	15.9 kg																
Double table	23.1 kg																
Triangular table	10.7 kg																
Trapezoidal table	19.0 kg																
Semicircular table	28.4 kg																
Lift group table	44.5 kg																
Flower group table	46.5 kg																
Workbench	75.0 kg																
Stackability	Triangular table, maximum four tables																
Optional accessories	Material box, wire basket, bag hook, chair suspension, table top with decorative elements: FLEX communication traffic light, FLEX stand absorber																

SO MANY SHAPES...

FLEX TABLE COLLECTION (SELECTION)

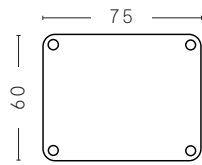

1401 Single table

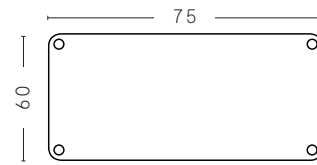

1402 Double table

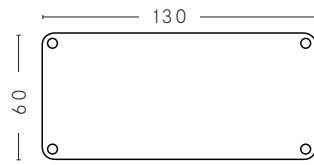

1411 Teacher's desk

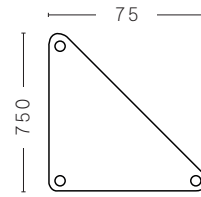

1403 Triangular table

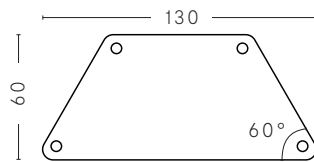

1405 Trapezoidal table

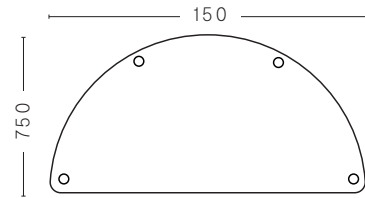

1409 Semicircular table

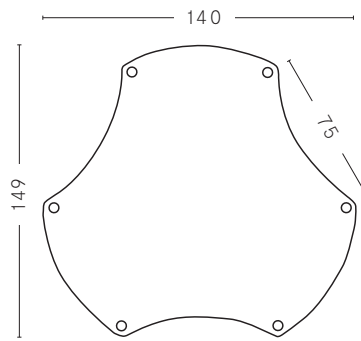

1407 Hub Group table

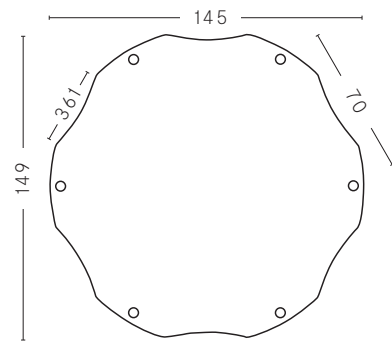

1410 Flower Group table

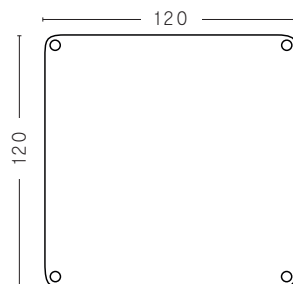

1408 Workbench

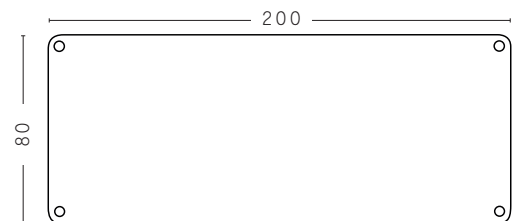



1441 Meeting table

GENERAL INFORMATION



NOTES

Planning data	Files for architects and planners available on request.
Tender documents	Please send us an email or give us a call, and we will promptly send you the requested texts about our products.
Certificates	Birch multiplex board (certificates GFA-COC-001456/GFA-PEFC-OC-500240), HPL (certificates SGSCH-COC-110039/DINC-PEFC-COX-000842). Available on request.
Cleaning & Care	Birch multiplex board with HPL surface 
	Powder-coated table legs 
BITTE BEACHTEN! Stapeln der Tische	When stacking FLEX TABLE tables with decorative elements (upside down – tabletop on tabletop), the tabletop must be covered to prevent scratching of the decorative elements or the tabletops.

Dimensions may vary due to material and production tolerances
Subject to technical changes, errors and colour variations.

WE LOOK FORWARD TO SEEING



FLÖTOTTO

	<p>Flötotto Einrichtungssysteme GmbH An der Manufaktur 4 33334 Gütersloh Germany</p>
Consultancy	<p>FLÖTOTTO is a key development partner for school authorities, architects, ministries and is in daily close contact with the teachers responsible in the respective schools. Together, we create flexible, age-appropriate educational spaces for intensive interaction between learners and teachers. The living and learning spaces we develop improve learning outcomes and, together with the architecture, ideally also have a positive impact on the immediate vicinity of the school location.</p> <p>We remain your first point of contact until the project is completed and even years afterwards.</p> <p>Get in touch with us, we will be happy to advise you!</p>
Contact for teachers & school administrators	<p>+ 49 5241 50474 0 lehrende@floetotto.com</p>
Contact for architectural firms	<p>+ 49 5241 50474 51 schulbau@floetotto.com</p>
Contact for school authorities	<p>+ 49 5241 50474 50 schultraeger@floetotto.com</p>
Contact for school authorities	<p>www.floetotto.com</p>
