



# FLEX Stage



Recommended use	School, learning spaces, open learning environments, libraries, creative spaces
Use	Grandstand table and seat combination
Execution	Legs made of powder-coated steel tubing (Ø 50 mm), which are firmly screwed to the multiplex board. Optionally with or without decorative element (Ø 50 mm) on the seat surface. Very sturdy, washable top made of sustainable birch multiplex material. Coated with HPL (28.6 mm).
Colours of table legs	 <p>05      09      06      73      11      31      16      54      04</p> <p>colour powder coated</p>
Table tops	High-quality, extra-strong birch multiplex board, raw and finely sanded edges, coated with HPL, thickness 28.6 mm. Both components are FSC and PEFC certified and come from ecologically, economically and socially sustainable forestry.
Edge finish	 <p>raw, finely ground</p> <p>oiled, finely sanded (for an additional charge)</p> <p>blackened, finely ground (for an additional charge)</p>
Castor	 <p>Double castor with locking function</p>
Weight	57 kg

PRODUCT INFORMATION

● 05 Snow White	RAL 9002	NCS S 1002-G50Y
● 09 Granite Grey	RAL 7037	NCS S 5000-N
● 06 Graphite Black	RAL 9005	NCS S 9000-N
● 73 Warm Grey	-	NCS S 5005-Y20R
● 11 Aqua Blue	RAL 210 70 10	NCS S 2020-B10G
● 31 Coral Red	RAL 040 40 60	NCS S 2070-Y80R
● 16 Sun Yellow	-	NCS S 0580-Y10R
● 54 Fern Green	-	NCS S 3020-G
● 04 Forest Green	RAL 6005	NCS S 7020-G

Height

Upper level: 76 cm  
Lower level: 38 cm

Measurements in cm

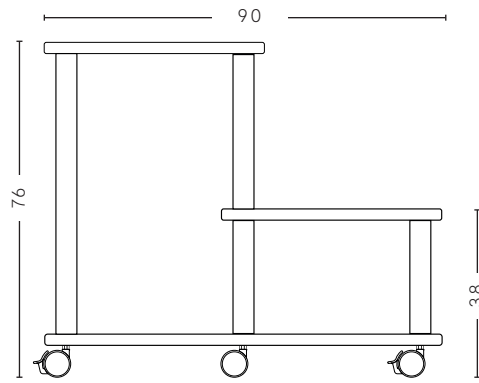
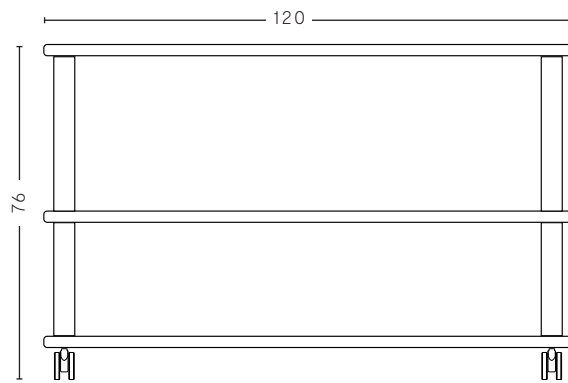

Can be combined with

PRO STOOL low  
FLEX BENCH

# GENERAL INFORMATION



---

Planning data

Files for architects and planners available on request.

---

Tender documents

Please send us an email or give us a call, and we will promptly send you the requested texts about our products.

---

Certificates

Birch multiplex board (certificates GFA-COC-001456/GFA-PEFC-OC-500240),  
HPL (certificates SGSCH-COC-110039/DINC-PEFC-COX-000842).  
Available on request.

---

Cleaning & Care

Birch multiplex board with HPL surface



Powder-coated table legs



---

Dimensions may vary due to material and production tolerances Subject to technical changes, errors and colour variations.

# WE LOOK FORWARD TO SEEING YOU



FLÖTOTTO

---

Flötotto Einrichtungssysteme GmbH  
An der Manufaktur 4  
33334 Gütersloh  
Germany

---

Consultancy

FLÖTOTTO is a key development partner for school authorities, architects, ministries and is in daily close contact with the teachers responsible in the respective schools. Together, we create flexible, age-appropriate educational spaces for intensive interaction between learners and teachers. The living and learning spaces we develop improve learning outcomes and, together with the architecture, ideally also have a positive impact on the immediate vicinity of the school location.

We remain your first point of contact until the project is completed and even years afterwards.

Get in touch with us, we will be happy to advise you!

---

Contact for  
teachers &  
school administrators

+ 49 5241 50474 0  
lehrende@floetotto.com

---

Contact for  
architectural firms

+ 49 5241 50474 51  
schulbau@floetotto.com

---

Contact for  
school authorities

+ 49 5241 50474 50  
schultraeger@floetotto.com

---

Contact for  
school authorities

www.floetotto.com

---